

## K-Shield Dynamax® Impact Belt Support System

**Engineered to Endure the Harshest Mining and Bulk Materials Handling Applications**



**K-Shield Dynamax® Impact Belt Support System** improves material containment at the conveyor's transfer point in very high impact applications.

Repeated impact from heavy lumps, long drop heights or lumps with sharp edges can potentially cause damage to the belt top cover. The centre of the K-Shield Dynamax® Impact Bed is suspended on anti-vibration mounts which significantly reduces the risk of belt damage. The K-Shield Dynamax® Impact Belt Support System features elastic properties that can effectively reduce the full force of the material stream compared to Impact Idlers or a conventional impact cradle.

### Key Design Features:

- Engineered to suit all bulk materials handling applications, particularly extreme mining environments.
- No rotating parts
- Modular design
- Energy absorbing mounts in impact zone
- Fixed wings for effective skirting
- Low friction UHMWPE Slider rails
- **Available in all belt widths**

The belt is supported on low friction, 30mm thick UHMWPE rails. Statically mounted wings provide a sag free region allowing an effective seal between the conveyor skirting system and belt.

The K-Shield Dynamax® Impact Belt Support System also delivers a simple drop-in replacement for existing impact idlers.

Each system is specifically engineered to match height and profile of the existing idlers.

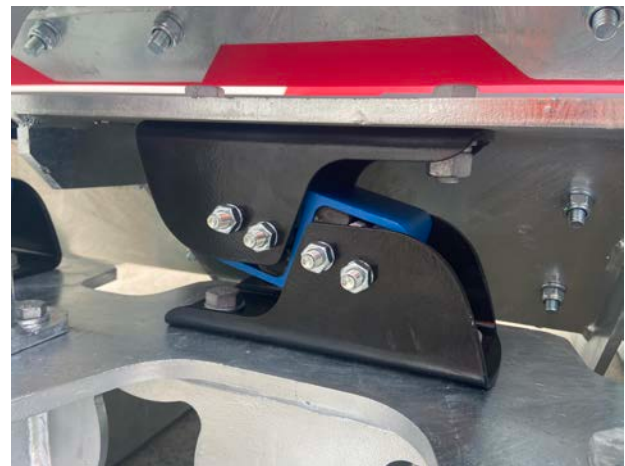

[kinder.com.au](http://kinder.com.au)

Subject to © Kinder Australia Pty Ltd

Issue: 202307

### Kinder Australia Pty Ltd

26 Canterbury Road, Braeside VIC 3195  
PO Box 1026, Braeside VIC 3195

☎ +61 3 8587 9111  
☎ +61 3 8587 9101

✉ [conveyorsolutions@kinder.com.au](mailto:conveyorsolutions@kinder.com.au)

ABN: 28 006 489 238

# K-Shield Dynamax® Impact Belt Support System

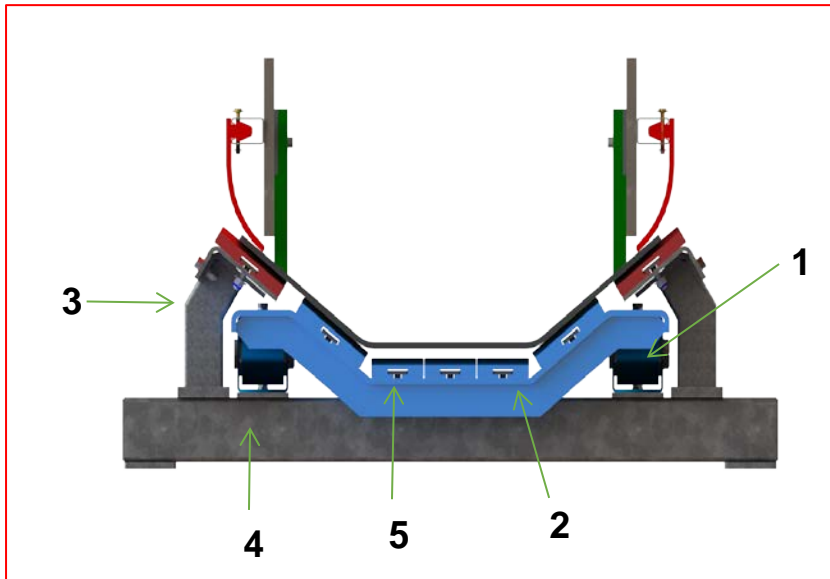

## K-Shield Dynamax® Impact Belt Support System

1. Energy absorbing anti-vibration mounts.
2. Dynamic trough suspended on anti-vibration mounts.
3. Fixed wings.
4. 100 x 100 x 8 RHS Transom.
5. Low friction UHMWPE Slider Rails.



**XHD Model Shown**



**With K-Glideshield® High Speed/Capacity Centre Rails Shown**

### High Capacity / Speed Belt Option

Designed to improve material containment at the conveyor's transfer point in ultra-heavy duty, very high impact applications.

Repeated impact from heavy lumps, long drop heights or lumps with sharp edges can potentially cause damage to the belt top cover.

K-Shield Dynamax® Impact Belt Support features a solid steel structure and manufactured with proprietary **K-Glideshield High Speed / Capacity Impact Bars**, suitable for the most demanding mining and high-speed applications.

[kinder.com.au](http://kinder.com.au)

Subject to © Kinder Australia Pty Ltd

Issue: 202307

### Kinder Australia Pty Ltd

26 Canterbury Road, Braeside VIC 3195  
PO Box 1026, Braeside VIC 3195

☎ +61 3 8587 9111  
☎ +61 3 8587 9101

✉ [conveyorsolutions@kinder.com.au](mailto:conveyorsolutions@kinder.com.au)

ABN: 28 006 489 238