

K-Calibre® U Type Secondary Belt Cleaner

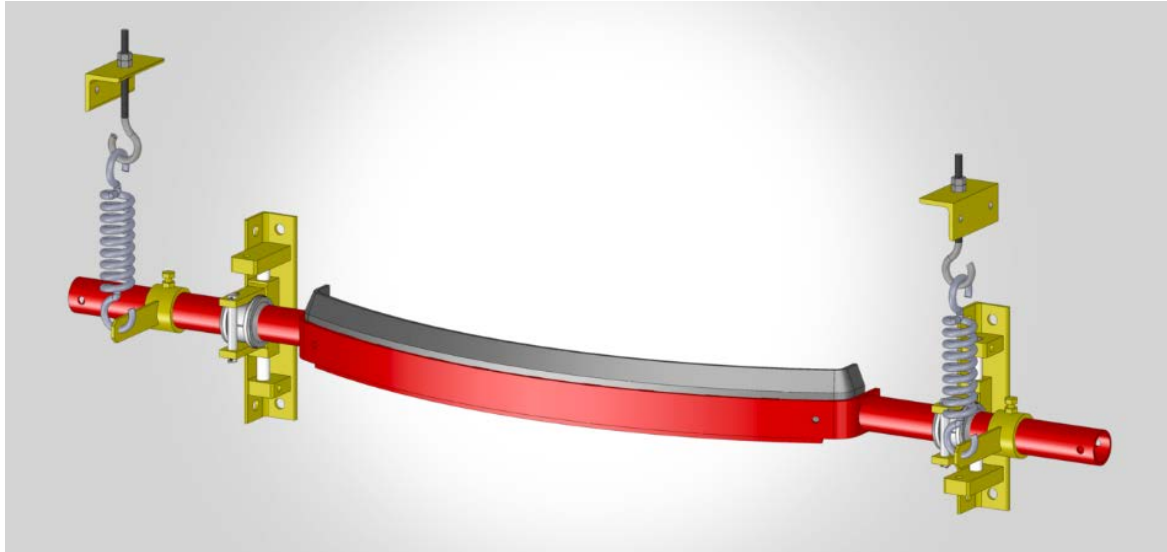

Cost-effective & Superior Cleaning Performance all in one.

K-Calibre U Type Belt Cleaner maintains a constant and uniform contact pressure across the whole width of the conveyor belt. Ideally used in applications where slurry and sticky carryback is present or excessive water removal is required.

Tungsten carbide blades deliver optimal cleaning performance, whilst vulcanised into a rubber mount absorbing any impact energy which minimises the transmission back into the conveyor belt, providing a belt friendly solution.

Blades are supplied as a single piece unit for easy slide-in and out replacement.



Features & Benefits:

Excellent Elasticity

- Tungsten carbide vulcanised into rubber mount.
- Belt Friendly.

Versatile Spring Tensioner

- Simplicity and economy of use.
- Low Maintenance.
- Easy to install and maintain.

Specification:

Belt Width	600-2000mm
Belt Speed	
Polyurethane Blade	≤ 4 m/s
Tungsten Blade	≤ 6.5 m/s
Cleaning Direction	One direction only
Blade Material	Tungsten Carbide or Polyurethane

kinder.com.au

Subject to © Kinder Australia Pty Ltd

Issue: 202111

Kinder Australia Pty Ltd

26 Canterbury Road, Braeside VIC 3195
PO Box 1026, Braeside VIC 3195

☎ +61 3 8587 9111
☎ +61 3 8587 9101

✉ conveyorsolutions@kinder.com.au

ABN: 28 006 489 238

K-Calibre® U Type Secondary Belt Cleaner

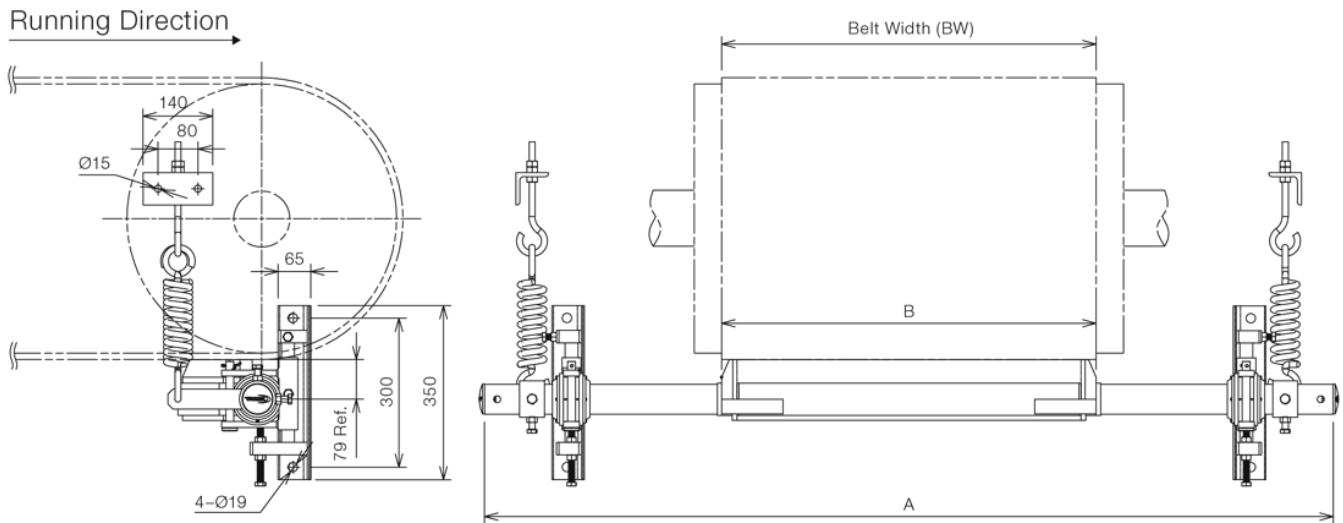

Belt Width	A	B	TUNGSTEN	POLYURETHANE
			Part Number Assembly	Part Number Assembly
450	1500	450	K-CLE-USTS-0450	K-CLE-USPS-0450
500	1550	500	K-CLE-USTS-0500	K-CLE-USPS-0500
600	1650	600	K-CLE-USTS-0600	K-CLE-USPS-0600
650	1750	650	K-CLE-USTS-0650	K-CLE-USPS-0650
750	1850	750	K-CLE-USTS-0750	K-CLE-USPS-0750
800	1900	800	K-CLE-USTS-0800	K-CLE-USPS-0800
900	1950	900	K-CLE-USTS-0900	K-CLE-USPS-0900
1000	2100	1000	K-CLE-USTS-1000	K-CLE-USPS-1000
1050	2150	1050	K-CLE-USTS-1050	K-CLE-USPS-1050
1200	2250	1200	K-CLE-USTS-1200	K-CLE-USPS-1200
1350	2400	1350	K-CLE-USTS-1350	K-CLE-USPS-1350
1400	2450	1400	K-CLE-USTS-1400	K-CLE-USPS-1400

kinder.com.au

Subject to © Kinder Australia Pty Ltd

Issue: 202111

Kinder Australia Pty Ltd

26 Canterbury Road, Braeside VIC 3195
PO Box 1026, Braeside VIC 3195

☎ +61 3 8587 9111
☎ +61 3 8587 9101

✉ conveyorsolutions@kinder.com.au

ABN: 28 006 489 238