

## K-Calibre® Secondary Belt Cleaner



### High Performance Tension Blade Combined with Spring Tensioner

**K-Calibre® Secondary Belt Cleaner** features a highly flexible secondary blade design, which can self-adjust and maintains blade-to-belt contact via a torsion element. The torsion-spring secondary mechanism ensures each blade bounces away from the belt for ideal splice passage and quickly returns to the cleaning position. This important feature effectively removes carryback and maintains a high cleaning performance, protecting the belt and its splices.

Carryback is a common occurrence within material handling operations, causing serious material accumulation and residue build-up on return rollers as well as productivity downtime and cleaning/maintenance issues if it adheres to the conveyor belt.

Similarly belt mistracking or belt-edge damage can also potentially result in unscheduled downtime. Depending on your specific application, **two materials of blades are available, tungsten carbide and PU**, which thoroughly scrape conveyor belts clean and eliminate problems with carryback and spillage.

#### Key Features

- High performance torsion blade combined with spring tensioner.
- Torsion element acts as a safeguard to protect the conveyor belt by allowing the blade to move away due to belt rips or in the case where belt fasteners may be used.
- Belt friendly.
- Excellent elasticity.
- Ideal for use on spliced belts.
- Simple and quick installation, adjustment and maintenance.



<https://kinder.com.au>

Subject to © Kinder Australia Pty Ltd  
Issue: 202103

### Kinder Australia Pty Ltd

26 Canterbury Road, Braeside VIC 3195  
PO Box 1026, Braeside VIC 3195

☎ +61 3 8587 9111  
☎ +61 3 8587 9101

✉ conveyorsolutions@kinder.com.au  
ABN: 28 006 489 238

# K-Calibre® Secondary Belt Cleaner

## Specifications

Cleaning direction – single direction only  
Belt Speed -  $\leq 4\text{m/s}$   
Blade Material – tungsten carbide an PU



## Running direction

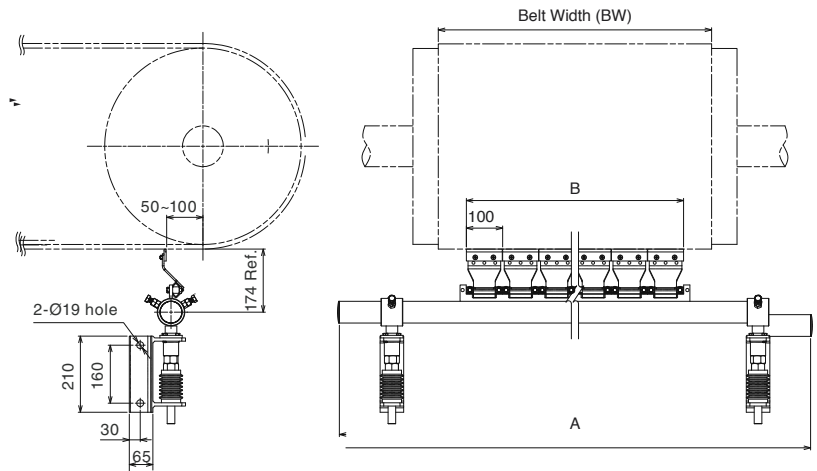

### Blade material

tungsten carbide and PU

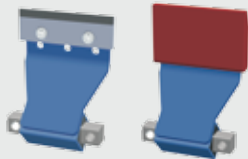

The blade bounces away from the belt for splice passage and quickly returns to the cleaning position.

### The torsion element

1. Simultaneously absorbing vibration and noise
2. Maintenance-free
3. No abrasion and wear problems

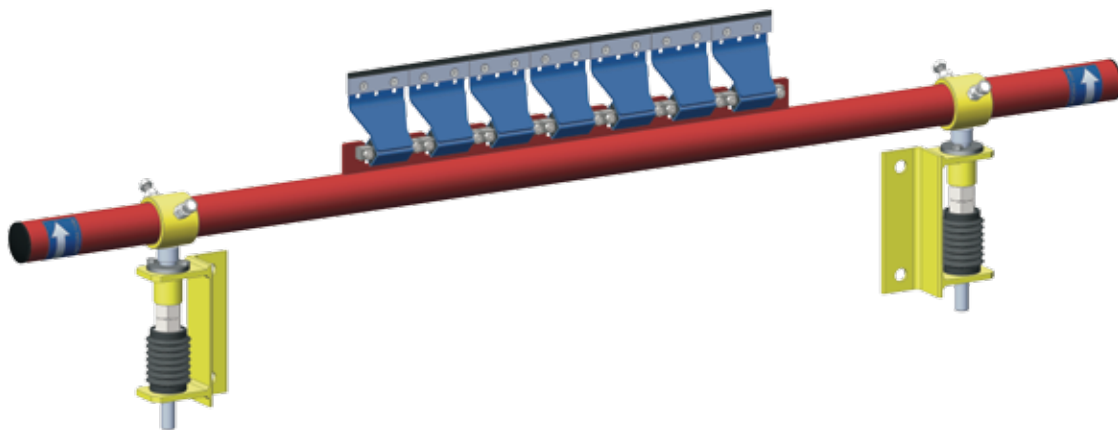
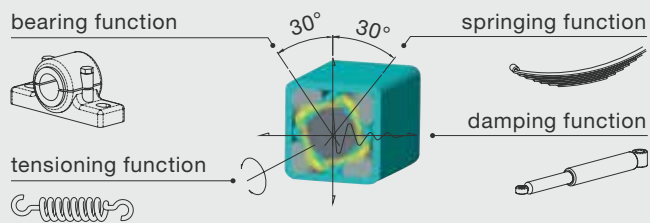

<https://kinder.com.au>

Subject to © Kinder Australia Pty Ltd  
Issue: 202103

## Kinder Australia Pty Ltd

26 Canterbury Road, Braeside VIC 3195  
PO Box 1026, Braeside VIC 3195

☎ +61 3 8587 9111  
☎ +61 3 8587 9101

✉ conveyorsolutions@kinder.com.au  
ABN: 28 006 489 238

## K-Calibre® Secondary Belt Cleaner



**K-Calibre® Reversing Cleaners** have a slide in/slide-out blade assembly design. This allows for quick and easy blade replacements, whilst helping to minimise conveyor downtime for reversible belts.

Carryback adhering to the belt can cause serious material accumulation and residue build-up on return rollers. This can lead to belt mistracking and/or belt-edge damage, resulting in unscheduled downtime. The reversible tungsten carbide belt cleaner blades thoroughly scrape conveyor belts clean and eliminate problems associated with carryback and spillage. In addition, the tungsten carbide vulcanised into rubber mount absorbs impact energy and minimises transmission back to the belt.

### Key Features:

<b>Belt width</b>	600-2000mm (24"-78")
<b>Belt Speed</b>	≤ 6m/s
<b>Cleaning direction</b>	Reversible direction
<b>Blade material</b>	Tungsten carbide

### Excellent elasticity

- Suitable for high-speed belts
- For reversible belts
- Tungsten carbide vulcanised into rubber mount

### Cost-saving spring tensioner

- Simplicity and economy of use
- Low maintenance

### Fast and easy installation

- Quick-change blades
- Belt-friendly



<https://kinder.com.au>

Subject to © Kinder Australia Pty Ltd  
Issue: 202103

### Kinder Australia Pty Ltd

26 Canterbury Road, Braeside VIC 3195  
PO Box 1026, Braeside VIC 3195

☎ +61 3 8587 9111  
☎ +61 3 8587 9101

✉ conveyorsolutions@kinder.com.au  
ABN: 28 006 489 238

# K-Calibre® Secondary Belt Cleaner

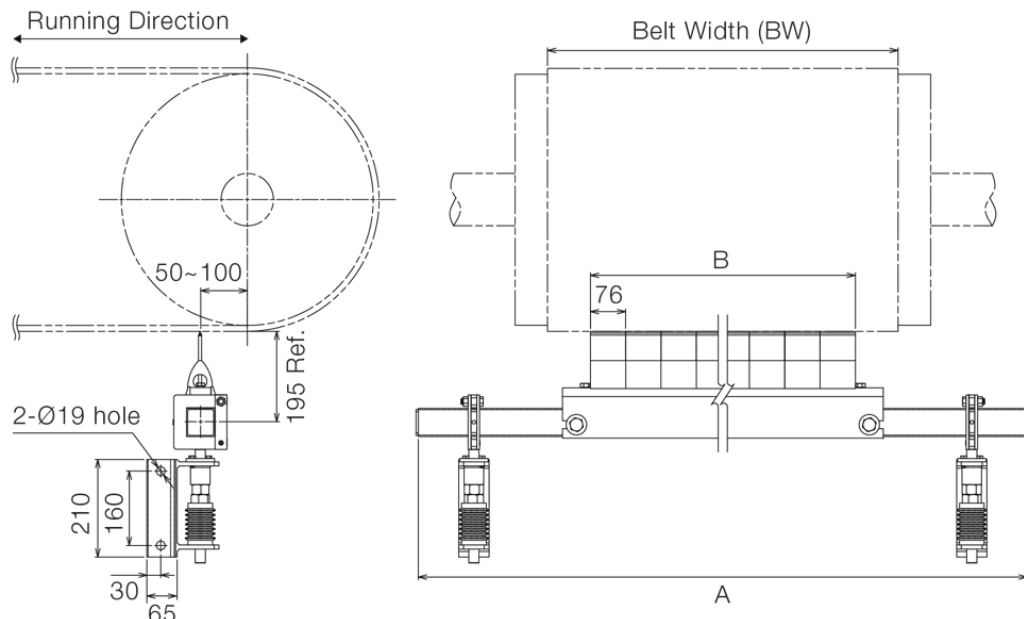

Belt Width	A	B	Blades Req.
600	1650	532	7
650	1750	608	8
750	1800	684	9
800	1900	760	10
900	1950	836	11
1000	2100	912	12
1050	2150	988	13
1200	2250	1140	15
1400	2450	1292	17
1600	2750	1520	20
1800	2950	1748	23
2000	3120	1900	25

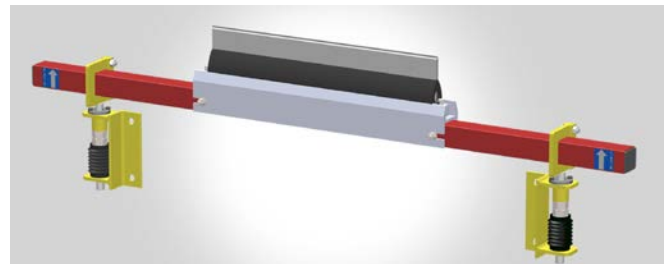

<https://kinder.com.au>

Subject to © Kinder Australia Pty Ltd  
Issue: 202103

## Kinder Australia Pty Ltd

26 Canterbury Road, Braeside VIC 3195  
PO Box 1026, Braeside VIC 3195

☎ +61 3 8587 9111  
☎ +61 3 8587 9101

✉ conveyorsolutions@kinder.com.au  
ABN: 28 006 489 238

